



TR-300EX

Left hand steering

GENERAL DATA

CRANE CAPACITY		30,000 kg at 3.0 m
BOOM		4-section, 9.1 m - 28.6 m
DIMENSION		
Overall length	approx.	11,000 mm
Overall width	approx.	2,620 mm
Overall height	approx.	3,530 mm
MASS		
Gross vehicle mass	approx.	27,000 kg
—front axle	approx.	13,500 kg
—rear axle	approx.	13,500 kg
PERFORMANCE		
Max. travelling speed	computed	50 km/h
Gradeability($\tan \theta$)	computed	57 % (at stall)

CRANE SPECIFICATIONS

MODEL

TR-300EX

CAPACITY

30,000 kg at 3.0 m

BOOM

4-section full length power telescoping boom of box construction with 5 sheaves at boom head. 3rd boom and top boom telescope synchronously by means of a double-acting cylinder, an extension cable and a retraction cable.

Hydraulic cylinders fitted with holding valves.

Fully retracted length9.1 m

Fully extended length28.6 m

Extension speed19.5 m in 90 s

JIB

2-staged swingaround boom extension. Triple offset(5°/ 25°/ 45°)type. Box type top section telescopes from lattice type base section which stores alongside base boom section.

Single sheave at jib head.

Length7.2 m and 12.8 m

SINGLE TOP (AUXILIARY BOOM SHEAVE)

Single sheave. Mounted to main boom head for single line work.

ELEVATION

By a double-acting hydraulic cylinder, fitted with holding valve.

Elevation speed0° to 80° in 46 s

HOIST—Main winch

2-speed type with grooved drum driven by hydraulic axial piston motor through winch speed reducer. Power load lowering and hoisting. Equipped with automatic fail-safe brake and counter-balance valve.

Controlled independently of auxiliary winch.

Single line pull31.4 kN {3,200 kgf}

Single line speed119 m/min (at the 4th layer)

Wire ropeSpin-resistant type

Diameter x length16 mm x 175 m

TADANO LTD.

HOIST—Auxiliary winch

2-speed type with grooved drum driven by hydraulic axial piston motor through winch speed reducer. Power load lowering and hoisting. Equipped with automatic fail-safe brake and counterbalance valve.

Controlled independently of main winch.

- Single line pull29.4 kN {3,000 kgf}
- Single line speed119 m/min (at the 4th layer)
- Wire rope.....Spin-resistant type
- Diameter x length16 mm x 90 m

SWING

Hydraulic axial piston motor driven through planetary swing speed reducer. Continuous 360° full circle swing on ball bearing slew ring. TADANO Twin Swing System to select power-controlled or free swing.

Equipped with manually locked/released swing brake.

- Swing speed3.0 min⁻¹ {rpm}

HYDRAULIC SYSTEM

- Pumps2 variable piston pumps for crane.
 - Tandem gear pump for steering and swing.
- Control valvesMultiple valves actuated by hand levers with integral pressure relief valves.
- CircuitEquipped with air cooled type oil cooler.
- Hydraulic oil tank capacity.....
 - approx. 410 liters
- FiltersReturn line filter

CAB

Both crane and drive operations can be performed from one cab mounted on rotating superstructure. One sided one-man type, steel construction with sliding door access and tinted safety glass windows opening at sides, rear and roof. Operator's 3 way adjustable seat with high back and seat belt.

TADANO Automatic Moment Limiter (Model:AML-L)

Main unit in crane cab gives audible and visual warning of approach to overload. Automatically cuts out crane motions before overload. With working range (load radius and/or boom angle and/or tip height) limit function.

Eight functions are constantly displayed.

Digital liquid crystal display:

- Either Boom angle or moment %
- Either boom length or potential hook height
- Either actual load radius or swing angle
- Actual hook load
- Permissible load
- Either jib offset angle or number of parts of line of rope
- Boom position indicator
- Either outrigger position or on-tire indicator

Bar graphical display:

- Either moment as percentage or main hydraulic pressure and torque converter oil pressure (Display changes by alternation key)

OUTRIGGERS

4 hydraulically operated outriggers. Each outrigger controlled simultaneously or independently from the cab. Equipped with sight level gauge. Floats mounted integrally with the jacks retract to within vehicle width. All jack cylinders fitted with pilot check valves.

- Extended width
 - Fully6,300 mm
 - Middle5,000 mm
 - Minimum2,200 mm
- Float size (Diameter)400 mm

COUNTERWEIGHT

Integral with swing frame.

- Mass1,890 kg

NOTE : Each crane motion speed is based on unladen conditions.

TYPE

Rear engine, left hand steering, driving axle 2-way selected type (by manual switch).

- 4 x 2 front drive
- 4 x 4 front and rear drive

FRAME

High-tensile steel, all welded box construction.

ENGINE

Model.....MITSUBISHI 6D16-TUA

Type.....4 cycle, turbo charged, 6 cylinder in line, direct injection, water cooled diesel engine.

Piston displacement7,546 cm³

Bore x stroke118 mm x 115mm

Max. output158 kW {215PS} at 2,800min⁻¹ {rpm}

Max. torque706 N·m {72 kgf·m} at 1,250min⁻¹ {rpm}

TRANSMISSION

Full automatic transmission.

Torque converter (with automatic lock up device at forward 2nd and 3rd) driving full powershift. 6 forward (3 for high range and 3 for low range) and 2 reverse (high range and low range) speeds, constant-mesh.

AXLES

Front.....Full floating type, steering and driving axle with planetary reduction.

RearFull floating type, steering and driving axle with planetary reduction.
Non-spin differential.

STEERING

Hydraulic power steering controlled by steering wheel.

Three steering modes available:

- 2-wheel front
- 4-wheel coordinated
- 4-wheel crab

SUSPENSION

Front.....Semi-elliptic leaf springs with hydraulic lockout device.

RearSemi-elliptic leaf springs with hydraulic lockout device.

BRAKE SYSTEM

ServiceAir over hydraulic disc brakes on all 4 wheels.

Parking / Emergency.....

Spring applied-air released brake acting on input shaft of front axle.

Auxiliary ..Electro-pneumatic operated exhaust brake.

ELECTRIC SYSTEM

24 V DC. 2 batteries of 12 V - 120 Ah capacity.

FUEL TANK CAPACITY

300 liters

TIRES

Front.....445/95R25(OR), Single x 2

Rear445/95R25(OR), Single x 2

TURN RADIUS

Min. turning radius (at center of extreme outer tire)

2-wheel steering 9.0 m

4-wheel steering 5.3 m

EQUIPMENT

STANDARD EQUIPMENTS

Automatic moment limiter (AML-L)

External lamp (AML)

Pendant type over-winding cutout

Winch automatic fail-safe brake

30 t capacity hook block (5 sheaves)

3 t capacity hook block (swivel hook)

Hook safety latch

Pilot check valves

Holding valves

Counterbalance valves

Hydraulic pressure relief valves

Swing brake

Swing lock

Boom angle indicator

Boom elevation foot pedal

Boom telescoping foot pedal

Sight level gauge

Electric windshield wiper and washer

Roof window wiper

Roof window unlock warning

Cloth covered cab seat

Tachometer/Speedometer

Cab floor mat

Sun visor (Front and roof)

Neutral position adjustable control lever (swing and/or auxiliary winch)

Automatic drive system

Transmission neutral position engine start

Overshift prevention

Parking braked travel warning

Tilt-telescope steering wheel

Back-up alarm

Air cleaner dust indicator

Air dryer

Water separator with filter

Engine over-run alarm

Hydraulic lockout suspension

Non-spin differential (Rear)

Towing eyes - front and rear

Seat belt (Driver's seat)

Hydraulic oil cooler

OPTIONAL EQUIPMENTS

Drum rotation indicator for main and auxiliary winch(Visual)

Cable follower

Tire inflation kit

Cab cooler

Cab heater and defroster (Diesel engine fuel oil)

Electric fan

Emergency steering

Reversing steering compensator

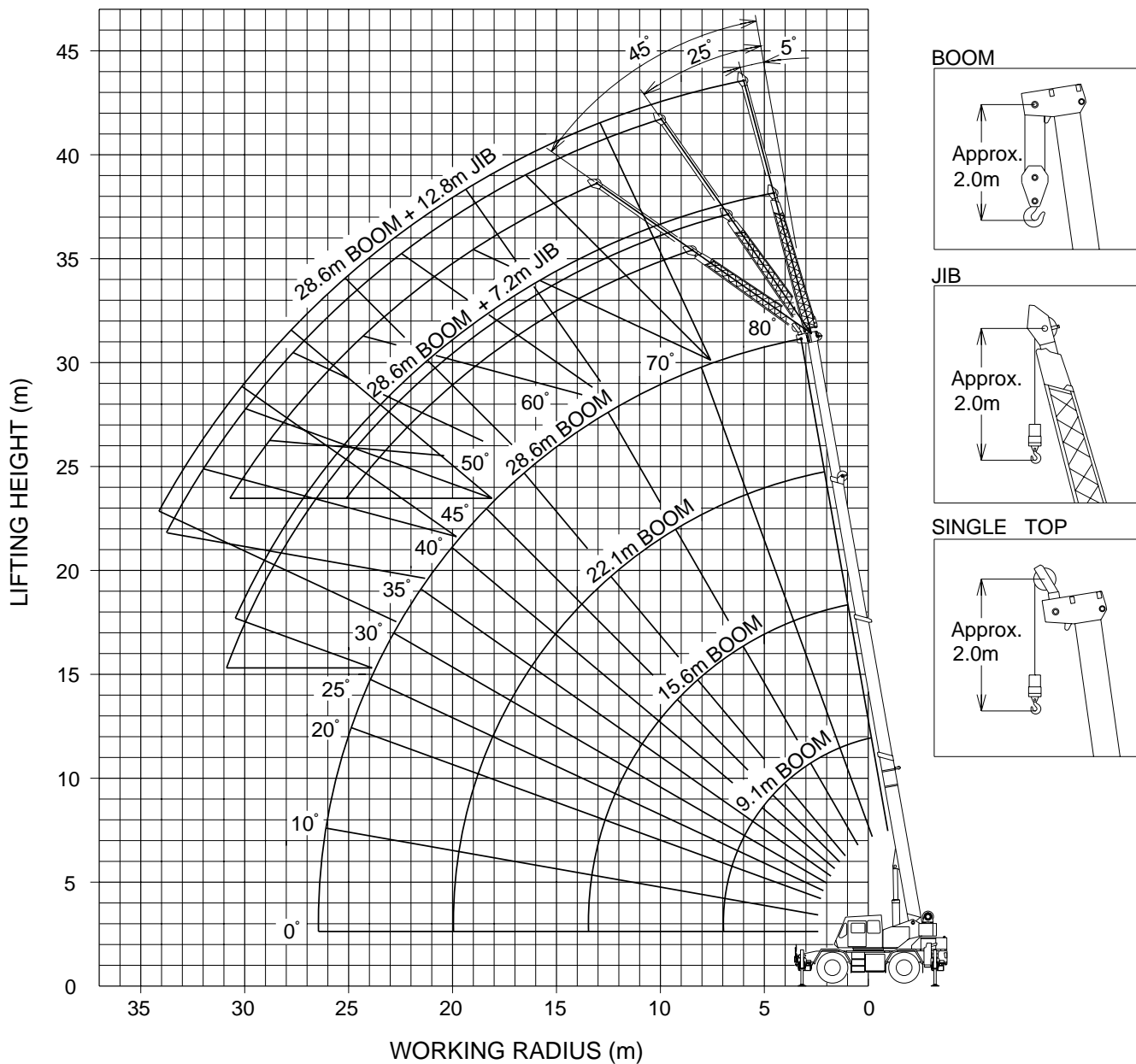

NOTE : The above lifting heights and boom angles are based on a straight (unladen) boom, and allowance should be made for boom deflection obtained under laden conditions.

ON OUTRIGGERS

Unit : kg

Outriggers fully extended (6.3 m) 360 ° Rotation				
B \ A	9.1	15.6	22.1	28.6
3.0	30,000	19,200		
3.5	25,000	19,200	12,500	
4.0	23,000	19,200	12,500	8,000
4.5	21,200	18,100	12,500	8,000
5.0	19,400	17,000	12,500	8,000
5.5	17,900	15,800	12,000	8,000
6.0	16,300	14,700	11,500	8,000
6.5	15,100	13,800	11,000	8,000
7.0		12,900	10,500	8,000
8.0		10,700	9,400	7,100
9.0		8,400	8,400	6,400
10.0		6,850	7,500	5,800
11.0		5,600	6,400	5,350
12.0		4,750	5,400	4,900
13.0		4,050	4,600	4,550
14.0			4,000	4,200
15.0			3,450	3,850
16.0			3,000	3,450
17.0			2,650	3,050
18.0			2,350	2,650
19.0			2,050	2,400
20.0				2,100
22.0				1,700
24.0				1,300
26.0				1,000

Unit : kg

Outriggers fully extended (6.3 m) 360 ° Rotation												
C	28.6 m Boom + 7.2 m Jib						28.6 m Boom + 12.8 m Jib					
	5 ° offset		25 ° offset		45 ° offset		5 ° offset		25 ° offset		45 ° offset	
	B	W	B	W	B	W	B	W	B	W	B	W
80 °	5.8	3,000	7.9	2,000	9.6	1,400	7.6	2,000	11.4	1,000	14.2	650
75 °	9.2	3,000	11.1	2,000	12.6	1,400	11.7	2,000	15.1	1,000	17.5	650
70 °	12.5	2,900	14.2	2,000	15.5	1,400	15.3	1,650	18.5	1,000	20.6	650
65 °	15.4	2,350	16.9	1,750	18.2	1,400	18.7	1,400	21.7	900	23.4	650
60 °	18.0	1,950	19.5	1,500	20.6	1,350	21.8	1,200	24.7	850	26.0	650
55 °	20.6	1,600	21.9	1,350	22.8	1,200	24.7	1,000	27.4	750	28.3	620
50 °	22.9	1,350	24.2	1,200	24.9	1,100	27.5	900	29.8	700	30.5	600
45 °	25.0	1,050	26.1	1,000	26.7	1,000	29.9	750	32.0	650	32.3	550
40 °	27.0	850	27.9	800			32.2	650	33.8	550		
35 °	28.7	600	29.4	600			34.0	450	35.3	400		
30 °	30.2	450	30.7	450			35.7	350				
25 °	31.4	350	31.8	350								

Unit : kg

Outriggers extended to middle (5.0 m) Over side				
B \ A	9.1	15.6	22.1	28.6
3.0	30,000	19,200		
3.5	25,000	19,200	12,500	
4.0	23,000	19,200	12,500	8,000
4.5	21,200	18,100	12,500	8,000
5.0	18,500	16,850	12,500	8,000
5.5	15,350	14,500	12,000	8,000
6.0	13,000	12,650	11,500	8,000
6.5	11,150	10,850	10,800	8,000
7.0		9,450	9,750	8,000
8.0		7,300	8,000	7,100
9.0		5,800	6,700	6,400
10.0		4,700	5,500	5,650
11.0		3,800	4,650	4,900
12.0		3,100	3,900	4,250
13.0		2,550	3,250	3,600
14.0			2,750	3,100
15.0			2,300	2,650
16.0			1,900	2,250
17.0			1,600	1,950
18.0			1,350	1,650
19.0			1,100	1,400
20.0				1,200
22.0				800

A : Boom length (m)
 B : Load radius (m)
 C : Boom angle
 W : Rated lifting capacity

ON OUTRIGGERS

Unit : kg

C	Outriggers extended to middle (5.0 m) Over side											
	28.6 m Boom + 7.2 m Jib						28.6 m Boom + 12.8 m Jib					
	5 ° offset		25 ° offset		45 ° offset		5 ° offset		25 ° offset		45 ° offset	
	B	W	B	W	B	W	B	W	B	W	B	W
80 °	5.8	3,000	7.9	2,000	9.6	1,400	7.6	2,000	11.4	1,000	14.2	650
75 °	9.2	3,000	11.1	2,000	12.6	1,400	11.7	2,000	15.1	1,000	17.5	650
70 °	12.5	2,900	14.2	2,000	15.5	1,400	15.3	1,650	18.5	1,000	20.6	650
65 °	15.3	2,100	16.9	1,750	18.2	1,400	18.7	1,400	21.7	900	23.4	650
60 °	17.8	1,400	19.5	1,350	20.6	1,250	21.8	1,100	24.7	850	26.0	650
55 °	20.3	900	21.8	850	22.7	800	24.5	650	27.3	550	28.2	500
50 °	22.6	550	23.9	500								

Unit : kg

Outriggers extended to minimum (2.2 m) Over side				
B \ A	9.1	15.6	22.1	28.6
3.0	12,700	9,950		
3.5	10,250	8,150	7,750	
4.0	8,000	6,800	6,650	6,250
4.5	6,600	5,700	5,750	5,450
5.0	5,400	4,850	5,000	4,800
5.5	4,500	4,150	4,350	4,250
6.0	3,850	3,550	3,800	3,800
6.5	3,200	3,000	3,350	3,350
7.0		2,600	2,950	3,000
8.0		1,850	2,300	2,400
9.0		1,200	1,750	1,900
10.0			1,350	1,500
11.0			950	1,200
12.0				900

A : Boom length (m)
 B : Load radius (m)
 C : Boom angle
 W : Rated lifting capacity

NOTES FOR "ON OUTRIGGERS" TABLE

- Rated lifting capacities shown in the table are based on condition that crane is set on firm level surface. Those above bold lines are based on crane strength and those below, on its stability.
- Retad lifting capacities based on crane stability are according to ISO 4305.
- The mass of the hook (350 kg for 30 t capacity, 100 kg for 3 t capacity), slings and all similarly used load handling devices must be added to the weight of the load.
- For rated lifting capacity of single top, reduce 350 kg from the relevant boom rated lifting capacity. Rated lifting capacity of single top should not exceed 3,000 kg.
- Standard number of parts of line for outrigger operation should be according to the following table. Load per line should not surpass 31.4 kN {3,200 kgf} for main winch and 29.4 kN {3,000 kgf} for auxiliary winch. The lifting capacity data stored in the AUTOMATIC MOMENT LIMITER(AML-L) is based on the standard number of parts of line listed in the chart. Maximum lifting capacity is restricted by the number of parts of line of AUTOMATIC MOMENT LIMITER(AML-L).

- The over-side rated lifting capacity depends on outrigger extension. Rated lifting capacity of over-front and over-rear assume fully extended outrigger position. Working area for each outrigger position are given separately and must be followed accordingly during operation.

Outrigger position	Middle	Minimum
Angle a°	25°	5°

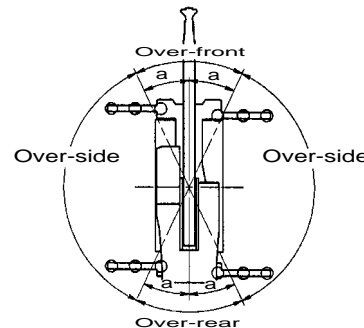

Boom length (m)	9.1	9.1 to 15.6	15.6 to 28.6	Jib/Single top
No. of part lines	10	6	4	1

ON TIRES

Unit : kg

A \ B	Stationary						A \ B	Creep					
	Over front			360°				Over front			360°		
	9.1	15.6	22.1	9.1	15.6	22.1		9.1	15.6	22.1	9.1	15.6	22.1
3.0	14,000	9,000		9,000	7,300		3.0	10,500	7,500		7,000	5,100	
3.5	14,000	9,000	6,500	7,800	7,300	4,500	3.5	10,500	7,500	5,500	6,300	5,100	3,200
4.0	12,500	9,000	6,500	6,600	6,100	4,500	4.0	9,500	7,500	5,500	5,600	4,900	3,200
4.5	10,900	9,000	6,500	5,500	5,100	4,500	4.5	8,700	7,500	5,500	4,800	4,400	3,200
5.0	9,800	8,200	6,500	4,600	4,300	4,300	5.0	8,000	7,000	5,500	4,000	3,800	3,200
5.5	8,700	7,500	6,100	3,850	3,600	3,900	5.5	7,100	6,400	5,250	3,400	3,200	3,100
6.0	7,600	6,800	5,750	3,200	3,000	3,450	6.0	6,150	5,900	5,000	2,800	2,650	2,900
6.5	6,600	6,200	5,400	2,650	2,500	3,000	6.5	5,300	5,300	4,750	2,350	2,200	2,650
7.0		5,600	5,050		2,050	2,650	7.0		4,900	4,450		1,800	2,350
8.0		4,500	4,400		1,500	2,000	8.0		3,900	3,900		1,300	1,750
9.0		3,500	3,800			1,500	9.0		3,100	3,400			1,300
10.0		2,750	3,250				10.0		2,400	2,900			
11.0		2,200	2,700				11.0		1,950	2,400			
12.0		1,800	2,250				12.0		1,550	2,000			
13.0		1,400	1,850				13.0			1,700			
14.0			1,500				14.0			1,300			

A : Boom length (m)
B : Load radius (m)

WORKING AREA

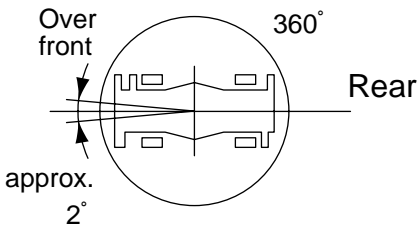

Without outriggers "Over front" operation should be performed within 2 degrees in front of chassis.

NOTES FOR "ON TIRES" TABLE

- Rated lifting capacities shown in the table are based on condition that crane is set on firm level surface, with suspension lock applied. Those above bold lines are based on tire capacity and those below, on crane stability. They are based on actual working radii increased by tire deformation and boom deflection.
- Rated lifting capacities based on crane stability are according to ISO4305.
- The mass of the hook (350 kg for 30 t capacity, 100 kg for 3 t capacity), slings and all similarly used load handling devices must be added to the weight of the load.
- For rated lifting capacity of single top, reduce 350 kg from the relevant boom rated lifting capacity. Rated lifting capacity of single top should not exceed 3,000 kg.
- Without outriggers lifting with "jib" is not permitted. Maximum permissible boom length is 22.1 m.
- CREEP is motion for crane not to travel more than 60 m in any 30 min. period and to travel at the speed of less than 1.6 km/h.
- During "CREEP" duties travel slowly and keep the lifting

- load as close to the ground as possible, and especially avoid any abrupt steering, accelerating or braking.
- Do not operate the crane while carrying the load.
- Tires should be inflated to their correct air pressure of 900 kPa {9.0 kgf/cm²} : 445/95R25
- Standard number of parts of line for on tires operation should be according to the following table.
The lifting capacity data stored in the AUTOMATIC MOMENT LIMITER(AML-L) is based on the standard number of parts of line listed in the chart. Maximum lifting capacity is restricted by the number of parts of line of AUTOMATIC MOMENT LIMITER(AML-L).

Boom Length(m)	9.1	9.1 to 22.1	Single top
No. of parts of line	6	4	1

DIMENSION

COTAC Oy

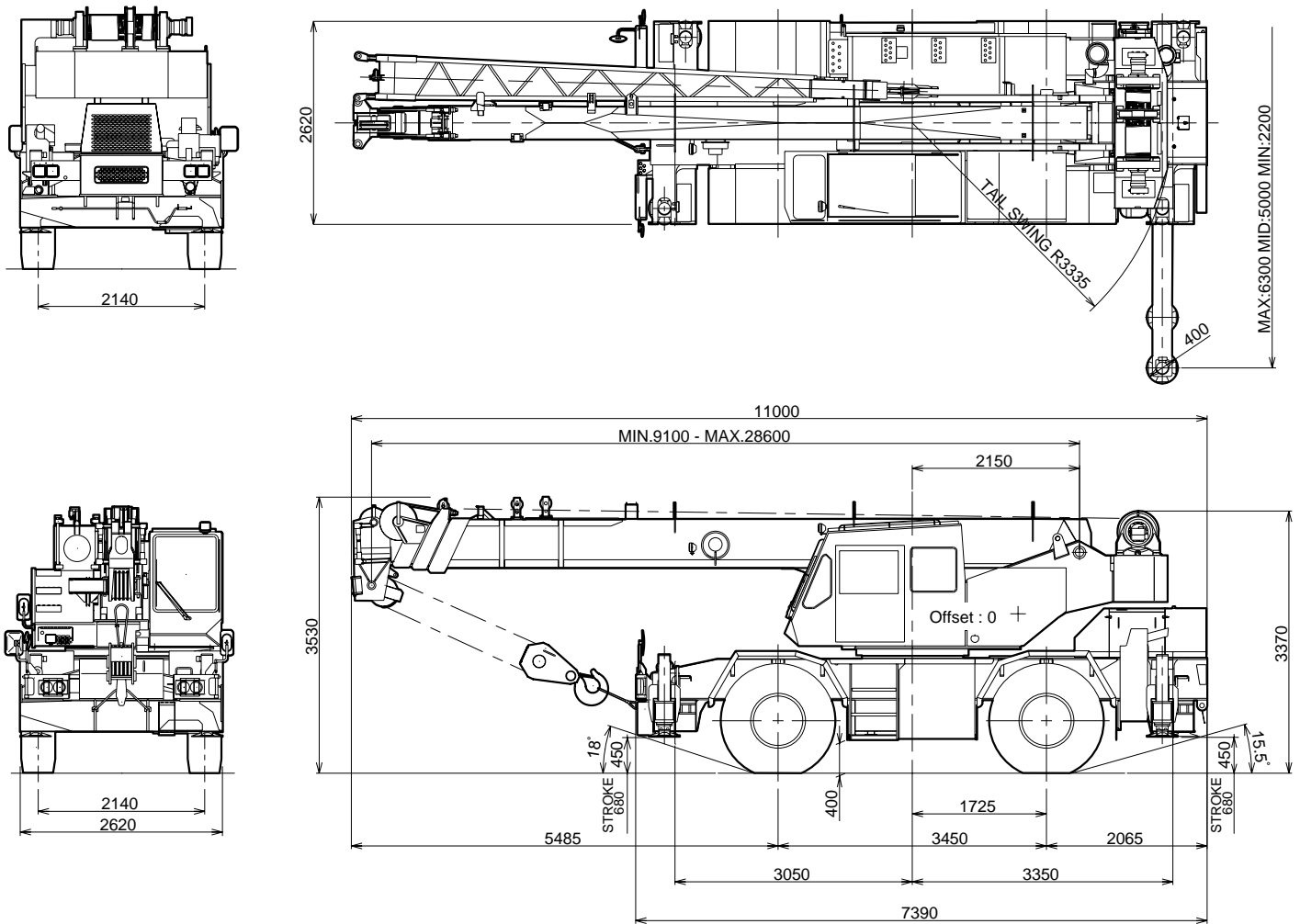

Specifications are subject to change without notice.



TADANO

TADANO LTD.